

ClassBuddy™ Locker 32

User Manual

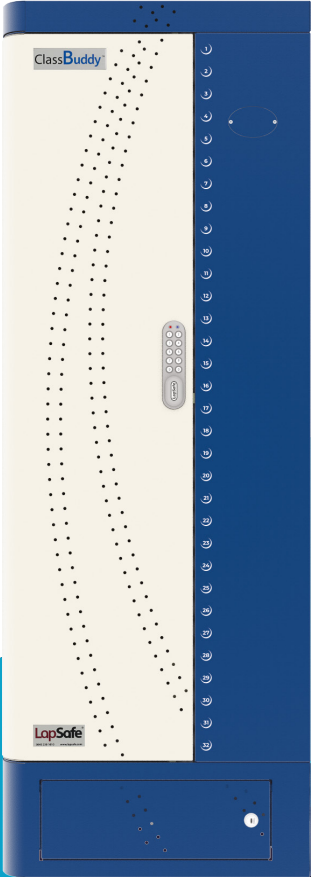

Contents

	Page No
Introduction	3
Important Actions	4
Warranty	5
Helpful Links	5
Overview	6
Installation	7
Front Door Operation	8
Power Sockets	8
Power Management Cassette	9
Thermal Trip	9
Installing AC Adaptors	11
Positioning the Charging Leads	12
Network Connectivity Option	13
Health & Safety	14
Modification	15
Cleaning	16
Care & Maintance	17
Safety Decleration	18
CE Certification	19

Introduction

Congratulations and thank you for purchasing a ClassBuddy™ Locker 32 from the LapSafe® ClassBuddy™ range. Your product comes with a lifetime parts and labour warranty which you will need to activate immediately.

This manual guides you through our recommendations for the set-up and correct use of the product.

Box Contents:

- 1 x ClassBuddy™ Locker 32
- 1 x User guide
- Set of Keys

Copyright Lapsafe® Self Service Solutions
Date: June 2020
Version: 1.0

Important actions

Upon delivery of your new ClassBuddy™ Locker 32 you must:

- Take a note and store in a safe place your product serial number which can be found on the silver plate on the side of the unit. You will need to quote this number for all enquiries relating to your unit.
- Take a note of your key number located on the key itself and store this in a secure place. You will need this if you wish to order additional keys.
- Visit lapsafe.com/support/activate-warranty to activate your Lifetime Warranty. Your warranty will not be valid unless you do this.
- Read the section on 'Health & Safety'.

Warranty

The ClassBuddy™ range comes with Lifetime Parts & Labour Warranty. Full details of our warranty are on our website lapsafe.com/warranty

To activate your FREE Lifetime* Parts and Labour Warranty, please go on-line and register at lapsafe.com/support/activate-warranty

Helpful Links



Support Enquiries

lapsafe.com/support/enquiry

support@lapsafe.com

0800 130 3456

Replacement Keys

lapsafe.com/support/keys

Warranty

lapsafe.com/support/

[activate-warranty](https://lapsafe.com/support/activate-warranty)

Warranty Details

lapsafe.com/warranty

Overview

Your ClassBuddy™ Locker 32 is supplied fully assembled, tested and ready for installation.

Each Classbuddy™ Locker 32 has a keyless lock on the front door and two additional, 'keyed alike' locks for access to the side compartment the lower front compartment.

We publish separate instructions for the use of the locks fitted on your particular ClassBuddy™ Locker 32.

The side compartment contains the power sockets for your AC adapters and there is a manufacturing option to have Euro power sockets.

The power to the sockets is controlled through a Power Management Cassette that is fixed in the top of the side compartment of your Classbuddy™ Locker 32.

Your ClassBuddy™ Locker 32 is supplied with a 2 metre mains lead.

Installation

The ClassBuddy™ Locker 32 is floor standing and because of its weight it must be secured to a wall to prevent any risk of it toppling forwards. An adjustable, anti-topple bracket is integrated into the top of the locker and can be adjusted to reach across a gap of up to 75mm to the wall.

Always use suitable fixings for the construction of the wall.

For set-up and to a lesser degree when in use, access will be required to the right-side compartment and both the mains power connection and the extractor fan (if fitted) are on this side so we recommend a gap of at least 150mm is left between the locker and the next item of furniture or wall.

Front Door Operation

Once the door lock is released the hinge allows the locker door to swing through approximately 150 degrees until it meets the side of the locker.



Do not let go of the door while it is moving.
Do not force the door in either direction.

Both of these actions could damage the door or the locker carcass.

Power Sockets

The locker power sockets are housed in the side compartment and they are designed to provide power for small loads up to a maximum of 90 watts per socket (nominal rating of the AC adapter).



UNDER NO CIRCUMSTANCES SHOULD A HEAVY LOAD BE PLUGGED INTO A SOCKET.

Power Management Cassette

The power management cassette in the top of your ClassBuddy™ Locker 32 may get warm when it is handling a significant electrical load for a period of time and this, in turn, may make the top of the locker feel warm to the touch.

This is completely normal and will cool down when the power demand reduces.

Thermal Trip

In the United Kingdom the detachable mains lead carries a fuse for the protection of users.

In the event that your ClassBuddy™ Locker 32 has been installed with no wall plug the power management cassette also has a resettable thermal trip. This trip acts in much the same way as a fuse to protect users and it can be re-set. The thermal trip is mounted on the back edge of the power management cassette in the top of the side compartment.

When the trip has operated there will be no power to the sockets and the centre button of the trip will be extended by approximately 12mm.

In the event of a trip:

1. First switch off the power supply and then check if the reason for the tripping is apparent and if possible correct the issue.
2. Allow at least 60 seconds after it has tripped and do not reset the trip with the mains power switched on.
3. Press the centre of the button back into the trip. When re-set the button will stay pressed in when you release your finger.
4. Restore power to the power cassette and check that the trip remains set.
5. If the trip operates again you should first switch off the mains and then switch off or unplug everything in the locker sockets.
6. Re-set the trip (items 2 and 3 above)
7. Restore power to the power cassette and check that the trip remains set.
8. Then, one by one, re-plug everything into the locker sockets, switch on and check that the trip remains set.

If the trip will not re-set or it continues to trip, there may still be a fault somewhere or the trip may have developed a fault. Please contact Support on 0800 130 3456 or support@lapsafe.com

Installing AC Adapters

First remove the side compartment door.

- Unlock and tilt the top of the door outwards.
- There is an earth strap onto the top of the door which will need to be disconnected by pulling the connector off the tab. (This connection must be reinstated when the door is replaced).
- Then gently lift the door out of its slots in the base of the locker and place it to one side.

Now the sockets and AC adapter storage shelves can be accessed.

- 'In-plug' AC adapters can be plugged directly into the sockets and the charging lead passed through the grommeted holes at the front of the locker.
- 'In-line' AC adapters can be loaded onto the shelves and secured behind the elastic strap before passing the charging leads through the grommeted holes and plugging the power leads into the sockets.

Positioning the Charging Leads

Open the front door of the locker and consider where the charging lead needs to be positioned based on the device that is to be stored/charged.

On the front right corner of each shelf there is a cable management slot that will hold the charging lead at the correct length to reach the charging port of the device. Make a small loop in the charging lead and pass it onto the slot. (The lead can be installed in the slot on the same shelf as its device or in the shelf above – whichever works best for your devices)

Feed any excess lead back through the grommet into the side compartment.

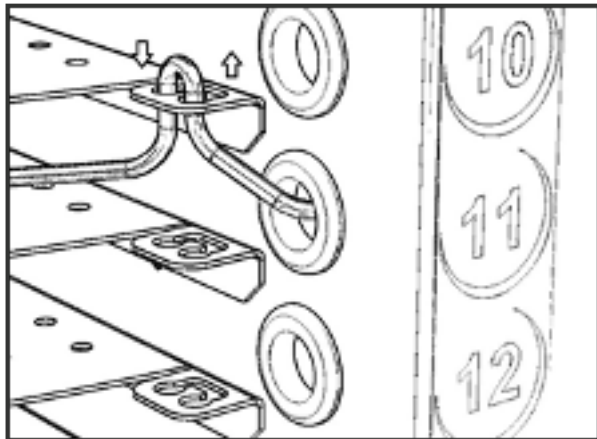

Network Connectivity Option

Below the front door there is a key controlled compartment that is ready to house a network switch or switches. (Netgear JSG524 or similar)

Power for the network switch/es can be fed down from the socket compartment into this compartment through the 30mm hole at the rear.

The network leads can pass up into the side compartment through the rectangular cut-out at the front of the locker.

An up-link lead can be passed through the hole at the right, rear of the locker, just above the power connection socket.

Adjust the length of the network leads onto each storage shelf and use the stud fixings beneath the fan cut-outs on the side of the locker to secure them in position.

Health & Safety

All products manufactured by LapSafe® have been thoroughly tested and certified by an authorised and INDEPENDENT testing house before sale.

Full CE compliance, which includes the requirements of LVD and EMC directives, is a STANDARD FEATURE of any solution manufactured by LapSafe®, as are many more built in safety features. CE Marking can be found on the product serial number plate, usually at the lower rear of the cabinet. CE Declaration of Conformity Certificate is issued with each product in the User Guide Pack.

Please be advised of the following safety advice:

At no time are the service areas of the ClassBuddy Locker 32 to be opened by anyone other than an authorised person.



WARNING: Hand and power tools can be dangerous when used incorrectly and the user should be trained to use work equipment and have an understanding of the HSE leaflet, ‘using work equipment safely’ (INDG229)

Please also refer to the manufacturers documentation for specific information about the equipment you are using.



WARNING: Because surfaces vary widely and the fitting location and method of fixing is out of LapSafe®’s control, it is imperative that you consult with appropriate engineering, architectural, or construction professional to ensure that your ClassBuddy™ Locker 32 is affixed properly and that the substrate is suitable to handle applied loads.



WARNING: Before removing or accessing any service area unplug or turn the power to the unit off.

IMPORTANT: Installation must be carried out by responsible persons and care should be taken when lifting the ClassBuddy™ Locker 32 into position.

Modifications



DO NOT MAKE ANY MODIFICATIONS TO THE WIRING OF YOUR CLASSBUDDY™ LOCKER 32

The power management cassette protects both users and devices against potentially harmful in-rush currents at start up, residual currents after power down and over current when in use.

Any modification to the power management system will negate your warranty and could make your ClassBuddy™ Locker 32 **dangerous to use**.

Cleaning



Do's

- Your ClassBuddy™ Locker 32 has a powder coat finish which is very durable and can be wiped clean using a mildly soapy cloth.
- To remove more stubborn marks or perhaps an adhesive residue you can use a gentle solvent such as white spirit or a mild solvent-based cleaner.



Don'ts

- **Do not** soak any areas of the locker
- **Do not** get the power cassette or the locker sockets wet
- **Do not** soak any area with solvent
- **Do not** use solvent cleaners on the locks

Care & Maintenance



Do's

- Lock your ClassBuddy™ Locker 32 when not in use, keep your keys in a safe place and not in the same room as the locker
- Read the Health and Safety guidelines in the user guide and share this information with all users
- Activate your warranty at lapsafe.com/support/activate-warranty
- Unplug charging leads before removing devices from the locker



Don'ts

- **Do not** leave keys in the doors
- **Do not** remove doors
- **Do not** modify the ClassBuddy™ Locker 32 in anyway without contacting LapSafe® first



Experts in Self-Service Solutions

Safety Declaration

Recent guidance from the Health and Safety Executive regarding "Laptop computer charging trolleys safety alert" requires interpretation from each manufacturer as regards to their product compliance. The HSE statement can be found at: www.hse.gov.uk/services/education/safety121009.htm

CE Testing, Conformity and Declaration of LapSafe®

At LapSafe® we are proud to confirm that ALL of our electrical products, going back over ten years, have been thoroughly tested and certified (by an authorised and INDEPENDENT testing house) and accordingly have been clearly CE marked.

Full CE compliance, which includes the requirements of LVD and EMC directives, is a STANDARD FEATURE of LapSafe®, as are many more "built in" safety features. CE Marking can be found on the product serial number plate, usually at the lower rear of the cabinet. CE Declaration of Conformity Certificate is issued with each product in the User Guide Pack.

You may obtain further copies of the certificate specific to your product and serial number, or any further information and advice, upon request to our Customer support- **call direct 01787 226147 or FREEPHONE the switchboard on 0800 130 3456 or email support@lapsafe.com**.

Rest assured that your LapSafe® Product has been designed and built with Safety as the highest priority since we first introduced the concept of the "mobile laptop trolley" into the UK market in the last century. This is, indeed, why we are called "Lap SAFE".

Residual Voltage

The HSE has raised a concern (having identified at least one particular manufacturer's trolleys with this "characteristic") that many manufacturers' trolleys (if indeed not the vast majority), may have a momentary residual voltage on the pins of the mains plug and that this could, if you touched the pins within a second or two of unplugging, result in an electric shock.

LapSafe® have been designed from the outset with safety internal circuitry as standard so as NOT to retain or present any significant residual voltage in this way. In fact, it is virtually impossible to get any such significant electric shock from our cabinets in normal use.

However, regardless of how safe any particular trolley may be, we endorse the recommendations for employing common sense practise as a generic rule for any mobile electrical appliance, such as switching off the mains socket before unplugging the power leads and NOT moving the trolleys without disconnecting and unplugging the power leads at both ends. Two of the wheels are fitted with locks as standard and should be kept locked as a reminder when power is connected and as a general safety rule as per the user instructions supplied with each cabinet.

For further information call LapSafe® on 0800 130 3456 or visit our website at lapsafe.com.

*Mentor™ range from January 2010



0800 130 3456
www.lapsafe.com

LAPSF076_23052011V2



EU Declaration of CE Conformity

EU Declaration of CE Conformity

to Council Directive 89/336/EEC
Amendment 2004/108/EC
&
to Council Directive 73/23/EEC
Amendment 2006/95/EC

Equipment Description:	Laptop Battery Charging Unit
Device Name:	LapSafe® ClassBuddy™ Range
Manufacture Address:	LapSafe® Unit 3 Wakes Hall Business Centre Wakes Colne Colchester Essex CO6 2DY
European Standards:	IEC 60950-1:2005 EN 60950-1:2006 + A1: 2010

Declaration: We hereby declare that the stated equipment complies with the required Emission, Immunity and Electrical Safety standards stated above.

Issue Date: 4 December 2012

Authorised by LapSafe®:

John Hutton

Position: Director

LAPSF199_04122012V1



0800 130 3456



sales@lapsafe.com



lapsafe.com



LapSafe® Self-Service Solutions Ltd

3 Wakes Hall Business Centre

Wakes Colne

Colchester

Essex

CO6 2DY

LapSafe® 